

Frameless Glass Shower Panel

10R 10C 10A

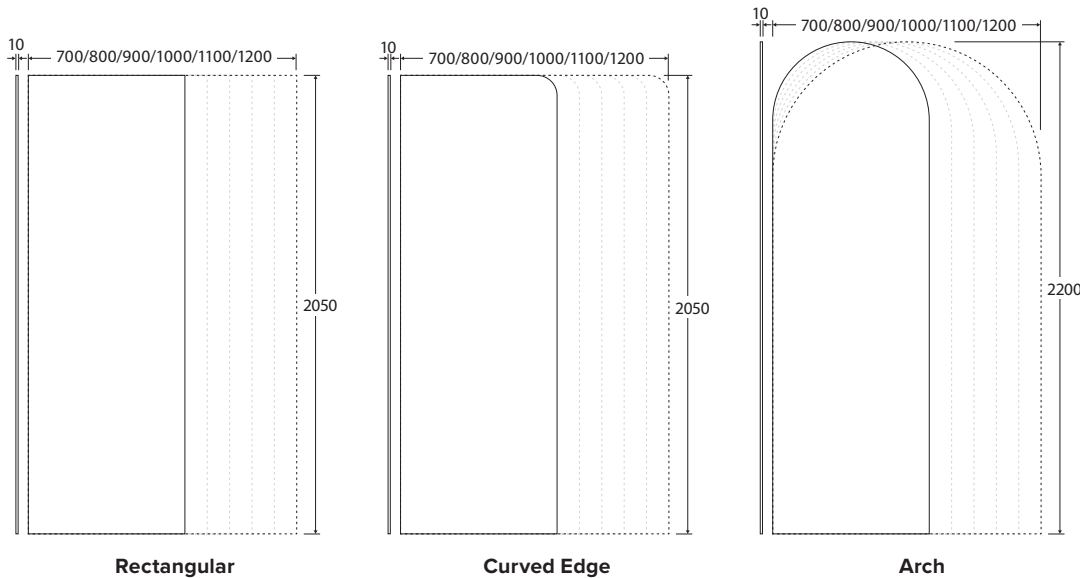

Important

INSTALLATION MUST ALWAYS BE CARRIED OUT BY A LICENSED TRADESPERSON

MINIMUM 2 PERSON LIFT WITH CARRYING AND INSTALLING SHOWER PANELS.

ENSURE ALL PANELS ARE INSTALLED WITH ADEQUATE BRACINGS



Safety information

- Always wear appropriate safety equipment.
- This product requires minimum of two people for lifting and installation.
- Be careful when handling this glass – damage to edges or surface scratches could lead to sudden breakage or cracking of the glass.
- Glass is most vulnerable when collided from the side.
- If Glass breaks, injuries may occur.
- If this product falls down, serious or fatal crushing injuries can occur. This product should be permanently fixed to the wall – contact your local fastening hardware retailer for advice on what fastening devices are suitable for your walls.



Cleaning & Care

- Clean regularly using a suitable glass cleaner and clean non abrasive cloth to avoid scratching.

BEFORE INSTALLATION: CHECK ALL PARTS OF PRODUCT THOROUGHLY. INSTALLATION IS ACCEPTANCE OF GOODS AND WILL VOID WARRANTY. GLASS PANELS ARE FRAGILE. TAKE EXTRA CARE WHILE TRANSPORTING AND HANDLING GOODS.

All installations should be carried out by a licensed tradesman in compliance and any State or Local Authority Regulations, in accordance with AS 1288:2021 – Glass in Buildings: Selection and Installation. All measurements are in millimetres and are subject to change without notice. Please refer to fienza.com.au for the latest product specification.

Shower Panel Parts

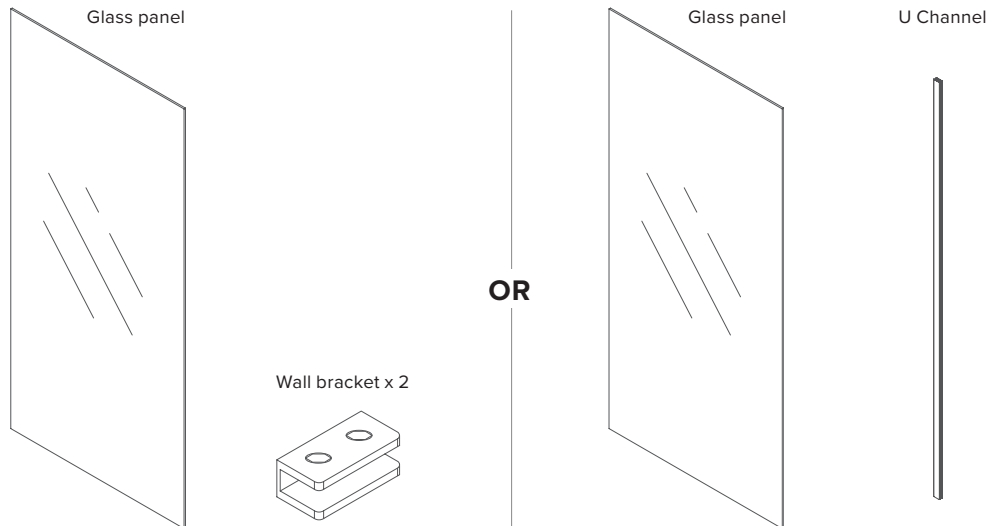

Installation

1. Set out location. Locate glass panel position on wall with level, by placing level line up wall to fit brackets for the position of glass. Measure for placement of brackets/U channel.

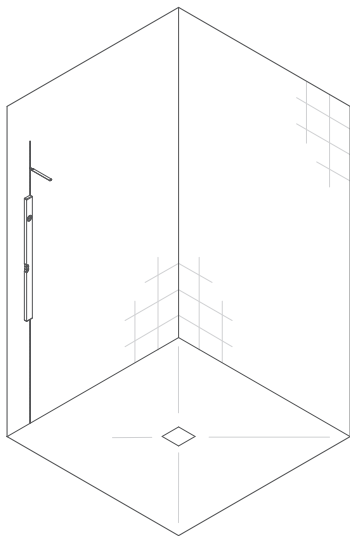

2. Once shower panel position has been confirmed, mark and drill holes for the brackets/U channel.

Tip: For Brackets this typically sits around the 200mm mark up from floor and 200mm down from top of panel.

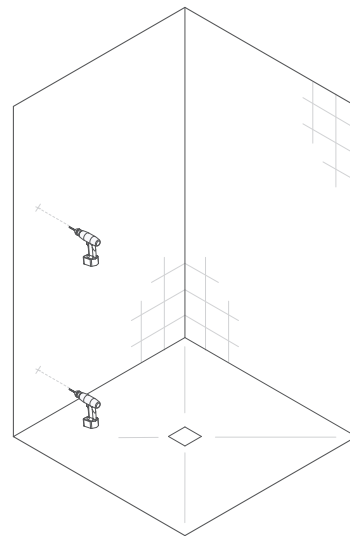

3. Screw brackets/U Channel to wall. (Screws not included)

Note: Minimum of 2 brackets must be used on every panel, additional brackets can be purchased online through Fienza or from your local fastening device retailer.

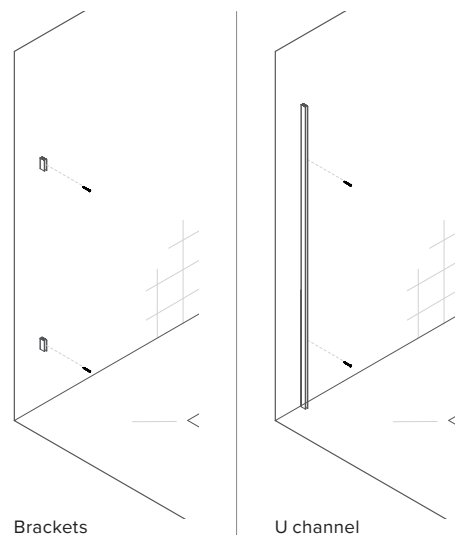

4. Once Wall fixings are secure, open glass panel box carefully. Place Packers (usually 3mm packers) on the floor where the panel will be installed.

Before lifting glass ensure you are wearing the appropriate safety equipment.

Before resting the glass on the floor ensure you have laid a protective sheet on the floor.

Fit glass on 3mm packers on the floor inserting glass into wall brackets or channel and cut packers back to be level with side of glass panel.

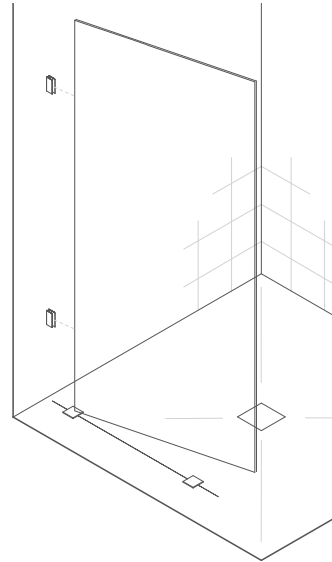
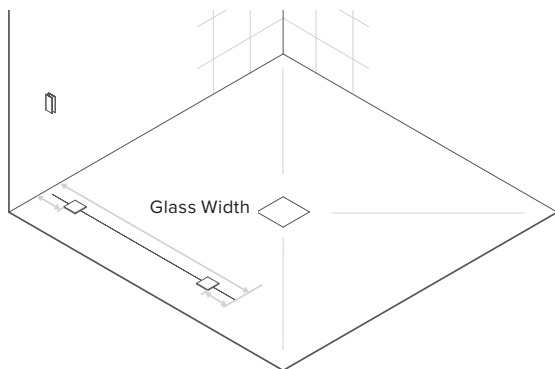

5. Seal shower screen in with silicone. A Neutral cure sanitary grade Silicone is recommended. Silicone needs to be capable of carrying the loads imposed by the glass, use a suitable nozzle which enables silicone to be adequately forced into the joint, excessive silicone should be removed before curing.

Tip: The success of the silicone bond with the glass is reliant on the cleanliness of the glass edge. Use a lint free cloth when applying a cleaner (Isopropyl alcohol or methylated spirits) to the glass prior to bonding.

Allow adequate curing time for silicone as per manufacturer's directions prior to running the shower.

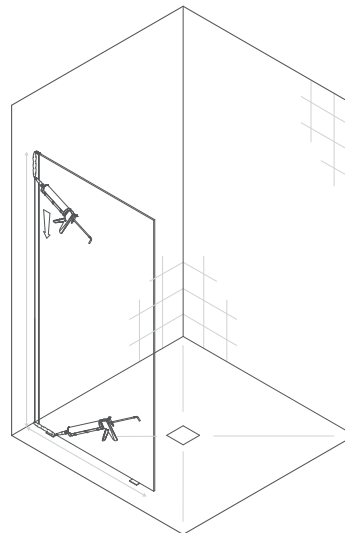

Important: Larger panels with a width especially over 1000mm, should be braced adequately with the proper bracing fastenings and/or supports. Additional Wall Brackets and or Bracings can be purchased online.

Australian Consumer Law

Our goods include guarantees that cannot be excluded under the Australian Consumer Law. You are entitled to a replacement or refund for a major failure and compensation for any other reasonably foreseeable loss or damage. You are also entitled to have the goods repaired or replaced if the goods fail to be of acceptable quality and the failure does not amount to a major failure.

Fienza Pty Ltd reserves the right to make changes in product characteristics, packaging or availability at any time without notice. Please visit fienza.com.au for the latest information.

Warranty Conditions

- Installation must be carried out by a licensed tradesperson in accordance with all applicable Building Codes and Federal, State, or Local Government Regulations, and in compliance with AS 1288:2021 Glass in Buildings – Selection and Installation.
- All maintenance and adjustments to the product after the installation have been carried out by a licensed tradesperson.
- All care and cleaning instructions have been adhered to as prescribed.
- All goods of substandard quality manufacture (excluding imperfections permitted within AS1976 - Vitreous China used in Sanitary Applications) will be credited or replaced by Fienza when advised within the warranty period, subject to prior inspection and agreement.
- Proof of purchase is required for warranty claims.

Warranty Limitations

To the extent permitted under the Trade Practices Act and other relevant legislation, Fienza's liability is limited to:

- The cost of replacing the goods, or
- The cost of obtaining equivalent goods, or
- The cost of having the goods repaired.
- Fienza is not responsible for any lack of operation or performance of goods (or any loss or damage) where goods are used or adapted for use with other goods not supplied by Fienza.
- It is the responsibility of the customer and installer before installation to ensure that all components are correct and free of obvious visible faults.
- Fienza is not responsible for the labour and rectification costs incurred in the above circumstance.

Conditions for On-Site Warranty Service Calls

Fienza will charge a service fee for each visit to an installation by its technician where it is determined that the fault is due to poorly executed or unlicensed installation work or where the product is not a genuine Fienza product or where the product is outside the warranty period. This may be paid in advance by credit card over the phone to a Fienza technician attending the site and will be refunded if the Fienza product is found to be at fault.



Full Warranty Terms

PLEASE LEAVE THIS MANUAL WITH THE END USER

For warranty support, please contact Fienza

15 Walter Cres, Lawnton QLD 4501 | PO Box 5381, Brendale QLD 4500

P 07 3490 6700 F 07 3490 6719 E help@fienza.com.au ABN 76 136 411 311